



# EDE707 7-Segment Display IC

## Octal Seven-Segment Display IC

EDE707			
Clock Input / Data Latch	1	<input type="checkbox"/>	CLK/Latch
+5V	2	<input type="checkbox"/>	+5V
No Connection	3	<input type="checkbox"/>	N/C
Digital Ground	4	<input type="checkbox"/>	GND
No Connection	5	<input type="checkbox"/>	N/C
Control Input #0 (LSB)	6	<input type="checkbox"/>	In 0
Control Input #1	7	<input type="checkbox"/>	In 1
Control Input #2	8	<input type="checkbox"/>	In 2
Control Input #3 (MSB)	9	<input type="checkbox"/>	In 3
Segment 'e' Enable	10	<input type="checkbox"/>	Seg. e
Segment 'd' Enable	11	<input type="checkbox"/>	Seg. d
Segment 'c' Enable	12	<input type="checkbox"/>	Seg. c
Segment 'b' Enable	13	<input type="checkbox"/>	Seg. b
Segment 'a' Enable	14	<input type="checkbox"/>	Seg. a
		<input type="checkbox"/>	+5V
		<input type="checkbox"/>	OSC1
		<input type="checkbox"/>	OSC2
		<input type="checkbox"/>	Digit 7
		<input type="checkbox"/>	Digit 6
		<input type="checkbox"/>	Digit 5
		<input type="checkbox"/>	Digit 4
		<input type="checkbox"/>	Digit 3
		<input type="checkbox"/>	Digit 2
		<input type="checkbox"/>	Digit 1
		<input type="checkbox"/>	Digit 0
		<input type="checkbox"/>	Flag
		<input type="checkbox"/>	Seg. f
		<input type="checkbox"/>	Seg. g
		<input type="checkbox"/>	28
		<input type="checkbox"/>	27
		<input type="checkbox"/>	26
		<input type="checkbox"/>	25
		<input type="checkbox"/>	24
		<input type="checkbox"/>	23
		<input type="checkbox"/>	22
		<input type="checkbox"/>	21
		<input type="checkbox"/>	20
		<input type="checkbox"/>	19
		<input type="checkbox"/>	18
		<input type="checkbox"/>	17
		<input type="checkbox"/>	16
		<input type="checkbox"/>	15

### Functionality & Feature Set:

- Easily controls up to eight 7-segment LED displays via 4-bit control bus
- Stores digit data and refreshes display without host intervention
- Digit-multiplexing reduces total display current draw
- Increment / Decrement / Clear counter functionality
- Full Hexadecimal character set (0123456789ABCDEF)
- Individual digit data loading
- Leading zero blanking
- Lamp test & all lamps off modes
- Zero overflow & countdown signal flag
- Operates with both common-anode or common-cathode displays
- Flicker-free display
- Available in 28 pin DIP, SDIP, or SOIC packages
- Interfaces to any microcontroller or microprocessor
- Cost effective for OEM applications

The EDE707 seven-segment LED controller handles up to eight 7-segment LED displays, tremendously reducing I/O demand on your host microcontroller as well as eliminating display refresh/scan software overheads. Data is written to the display via a 4-bit data bus using an active-low latch pin. Display data is sent to the unit in BCD (binary-coded decimal) format and is continuously displayed by the EDE707 until the host system provides new data. The EDE707 offers a valuable feature set, including leading zero blanking, counter functionality, an overflow flag, and a full 0-9,A-F Hex character set.

## PIN DEFINITIONS

### Segment Connection Pins:

(Seg. a) Segment 'a' Enable (Pin 14)..... Connect to segment 'a' drive transistor's base resistor  
 (Seg. b) Segment 'b' Enable (Pin 13)..... Connect to segment 'b' drive transistor's base resistor  
 (Seg. c) Segment 'c' Enable (Pin 12)..... Connect to segment 'c' drive transistor's base resistor  
 (Seg. d) Segment 'd' Enable (Pin 11)..... Connect to segment 'd' drive transistor's base resistor  
 (Seg. e) Segment 'e' Enable (Pin 10)..... Connect to segment 'e' drive transistor's base resistor  
 (Seg. f) Segment 'f' Enable (Pin 12)..... Connect to segment 'f' drive transistor's base resistor  
 (Seg. g) Segment 'g' Enable (Pin 15)..... Connect to segment 'g' drive transistor's base resistor

### Display Module Common-Anode/Cathode Connection Pins:

Digit 0 (Pin 18)..... Connect to Digit 0 drive transistor's base resistor  
 Digit 1 (Pin 19)..... Connect to Digit 1 drive transistor's base resistor  
 Digit 2 (Pin 20)..... Connect to Digit 2 drive transistor's base resistor  
 Digit 3 (Pin 21)..... Connect to Digit 3 drive transistor's base resistor  
 Digit 4 (Pin 22)..... Connect to Digit 4 drive transistor's base resistor  
 Digit 5 (Pin 23)..... Connect to Digit 5 drive transistor's base resistor  
 Digit 6 (Pin 24)..... Connect to Digit 6 drive transistor's base resistor  
 Digit 7 (Pin 25)..... Connect to Digit 7 drive transistor's base resistor

### Control Inputs, Outputs:

In 0 (Pin 6)..... Control Input Bus Pin #0 (LSB)  
 In 1 (Pin 7)..... Control Input Bus Pin #1  
 In 2 (Pin 8)..... Control Input Bus Pin #2  
 In 3 (Pin 9)..... Control Input Bus Pin #3 (MSB)  
 CLK / Latch (Pin 1)..... Clock Input / Data Latch (Active Low Input)  
 Flag (Pin 17)..... Zero Detect Flag (Active High Output)

### Clock / Power Pins:

OSC1 (Pin 27)..... One pin of 4MHz parallel-cut  
 crystal or resonator, or a direct  
 TTL clock input  
 OSC2 (Pin 26)..... Other pin of 4MHz parallel-cut  
 crystal or resonator, or leave  
 floating if OSC1 driven with  
 a TTL clock input  
 +5V (Pins 2,28)..... Connect to +5V DC  
 GND (Pin 4)..... Connect to 0V DC (Ground)

*Note: DIP, SDIP, & SOIC (surface mount) packages of the EDE707 have identical pinouts. Please specify EDE707 /P, /SP, or /SO respectively when ordering. Inquire about SSOP packaging and pinout.*

## OVERVIEW OF OPERATION

The EDE707 Seven-Segment LED Interface IC is designed to control from one up to eight 7-segment LED displays. These displays are connected to the EDE707 via NPN transistors (2N2222 or equivalent) as illustrated in Figures One and Two. Note that the EDE707 can be used with either common-anode or common-cathode type displays.

Digit display data is loaded into the EDE707 in binary-coded decimal (BCD) format (Example: 0011 = '3'). Alternately, the EDE707 may be used as a low frequency increment/decrement counter. Power-up state is: all LED displays activated and reset to 0, leading zeros displayed.

The EDE707 requires a clock input, which can be either a 4MHz resonator, 4MHz parallel-cut crystal (15-22pF load capacitors recommended), or other oscillator source (see OSC1 & OSC2 pin descriptions on page 2). This oscillator controls the internal timing of the EDE707 and causes the displays to be continuously multiplexed to provide flicker-free illumination of the entire display.

You'll note in the hookup schematic that the LED segment resistors' values seem low (10 Ohms, ¼ to ½ Watt for a standard display; use higher resistance for high-efficiency displays), seemingly drawing excessive current. However, because the digits are not continuously being driven, but are actually being scanned by the refresh circuitry one display at a time (ON 12.5%, OFF 87.5%), the overall duty cycle must be factored in to determine true current draw. Make certain that the resistors chosen are capable of the current requirements of the LED displays selected. Segment current can be approximated by the formula:  $0.125(3.8/R)$ , where 0.125 is the 'ON' period of the duty cycle, 3.8 is the supply voltage minus the two transistor voltage drops, and R is the segment series resistor value. LED brightness can be adjusted with this resistor value; for outdoor applications use high-efficiency LED displays.

**Additional Note:** The clock source must always be connected to the EDE707 during circuit operation; failure to do so will prohibit the refresh cycle and leave one display on continuously, possibly causing excessive current flow.

## CONNECTING & CONTROLLING THE EDE707

Data and commands are sent to the EDE707 via the four input pins In3..In0 (pins 9..6). This input bus is read by the EDE707 on the falling edge of the CLK/Latch input (pin 1) (See Table Two for data bus setup and hold times). The following table illustrates the command set available on the EDE707:

IN3-IN0	ACTION:
0abc	The next byte received is the value for digit 'c'
1000	Increment current counter value by one
1001	Decrement current counter value by one
1010	Reset all displays to zero (00000000)
1011	Lamp test (88888888)
1100	Turn entire display off
1101	Turn entire display on (default)
1110	Blank leading zeros
1111	Show leading zeros (default)

Table One: EDE707 Command Set

For example, suppose your circuit has just been powered up with eight displays connected. By default, the displays read all zeros (00000000). If the command '1000' is sent to the EDE707, the least significant digit will be increased by one, and the display will now read 00000001.

As a second example, suppose you wish to individually load each digit with a value, so that the display reads, for example, 12345678. To start loading the data at the leftmost digit, you would first send the command '0111', telling the EDE707 that the next byte it receives should go into position 111 binary, or Digit 7 (see Table One). You would then send 0001, the digit value for the leftmost display. This [address,data] sequence is followed for the remaining displays until each digit displays the desired value. Now the EDE707 can be ignored by the host microcontroller and it will continuously display the current digit data until the host alters the displayed value.

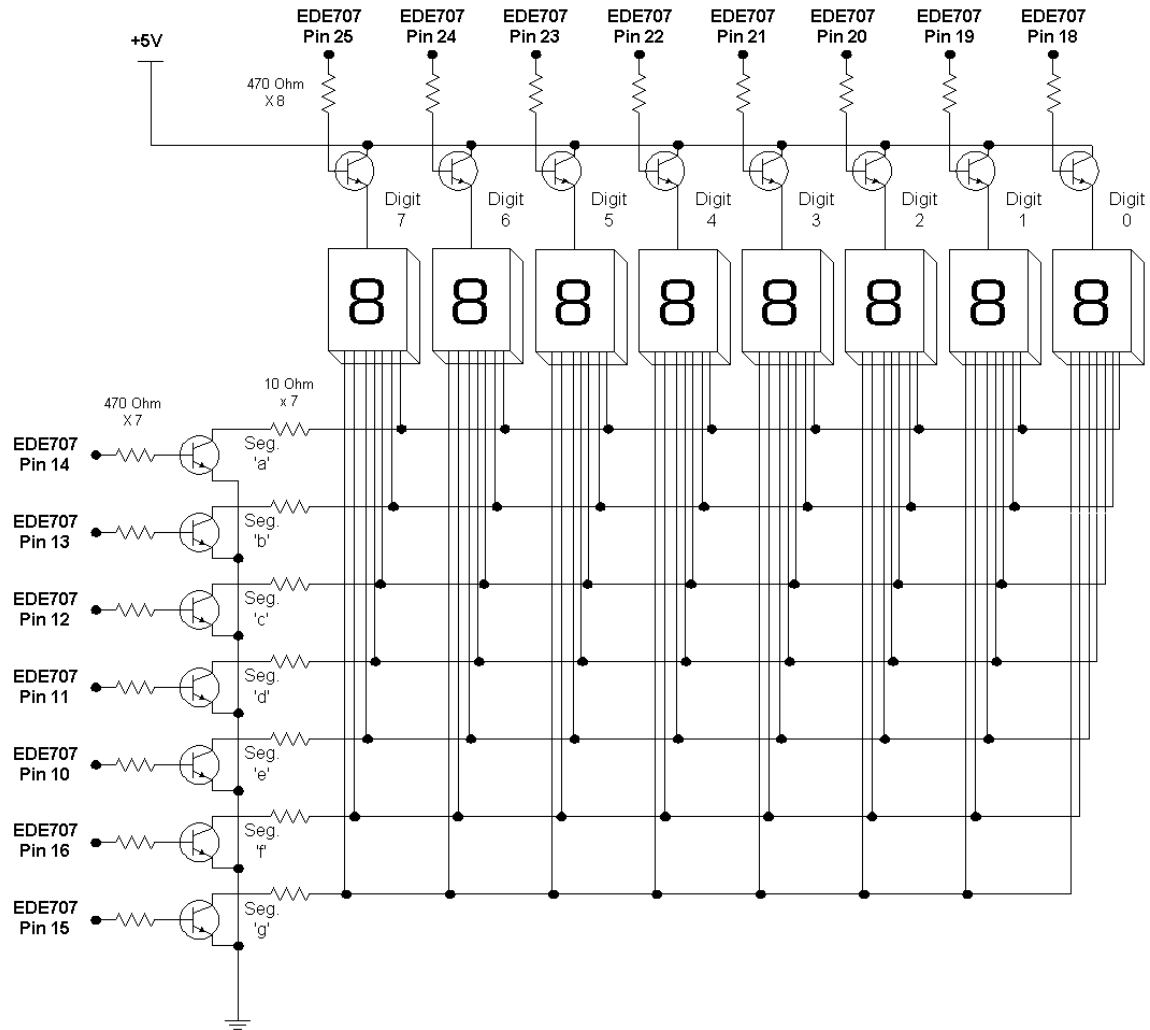

Figure One: Connection to Common-Anode Displays

The use of 470 Ohm base resistors (1/8<sup>th</sup> Watt) from the EDE707 Digit and Segment output pins is very important; failure to include them can result in excessive current flow and possible component damage. Figure One illustrates the proper connection for common-anode displays. As illustrated, the displays' common anodes are supplied +5V via an emitter-follower transistor arrangement, and the segment cathodes are grounded using a common-emitter arrangement. Alternately, for common cathode displays (as illustrated in Figure Two below) the transistor drive arrangements are reversed.

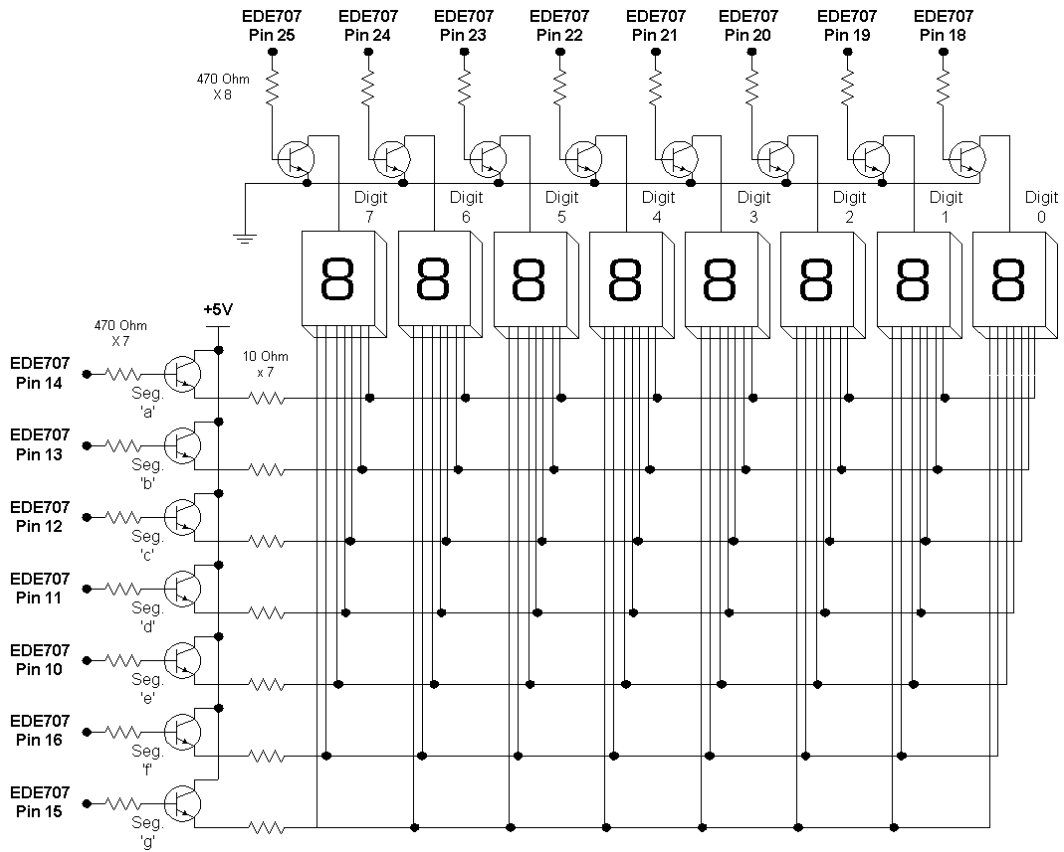
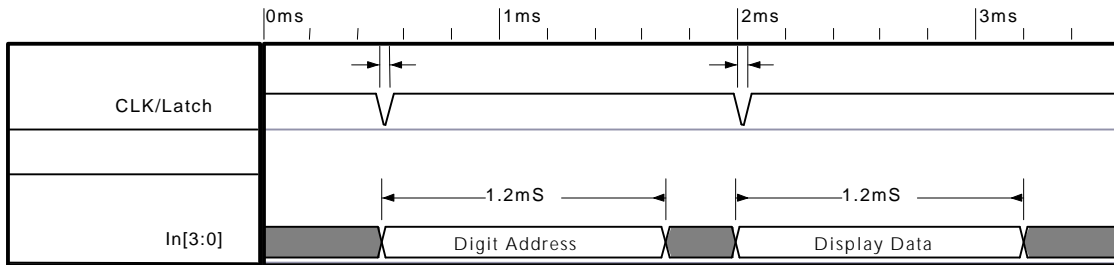

Figure Two: Connection to Common-Cathode Displays

### TIMING OVERVIEW



The following table specifies the data bus setup & hold time (as seen above) prior to the CLK/Latch (pin 1) activation, as well as the maximum clock speed for counter operations:

Parameter	Value
Input Bus (pins 9..6) Setup Time	0 nS
Data Bus Hold Time	1.2 mS
CLK/Latch (pin 1) minimum pulsewidth	30 nS

Table Two: Timing Data

Please note that while zero setup time is required of the input bus, the data must be held on the bus for 1.2mS (1200uS) following the negative edge of the CLK/Latch signal to ensure that the EDE707 is able to complete its current scan cycle before latching the incoming data.

## LED DISPLAY PATTERNS

The EDE707 has a build-in font table to display the characters 0,1,2,3,4,5,6,7,8,9,A,B,C,D,E,F. The following table indicates the segments active for each BCD input value:

BCD Input	Value	a	b	c	d	e	f	g
0000	0	1	1	1	1	1	1	0
0001	1	0	1	1	0	0	0	0
0010	2	1	1	0	1	1	0	1
0011	3	1	1	1	1	0	0	1
0100	4	0	1	1	0	0	1	1
0101	5	1	0	1	1	0	1	1
0110	6	1	0	1	1	1	1	1
0111	7	1	1	1	0	0	0	0
1000	8	1	1	1	1	1	1	1
1001	9	1	1	1	1	0	1	1
1010	A	1	1	1	0	1	1	1
1011	B	0	0	1	1	1	1	1
1100	C	1	0	0	1	1	1	0
1101	D	0	1	1	1	1	0	1
1110	E	1	0	0	1	1	1	1
1111	F	1	0	0	0	1	1	1

Table Three: Segment Activation Pattern

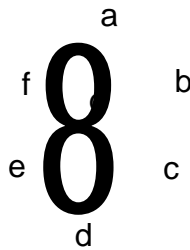

FigureThree: Segment Connection Pattern

## COUNTER FUNCTIONALITY

Counter functionality has been added to the EDE707 to enable it to serve as a stand-alone increment/decrement counter and display controller. The counter uses base ten digits (0-9), and is capable of displaying from values from 0 to 99,999,999. With the value '1000' on the Input Bus, the displayed count value increments by one for each falling edge of the CLK/Latch Pin (pin 1). Similarly, the value '1001' causes the current counter value to be decremented by one. The value '1010' resets all digits to zero. The counter will automatically roll-over on overflow and underflow. Leading zeros can be blanked or displayed; see Table One for appropriate commands. Maximum count speed is 800 increments or decrements per second.

The 'Zero Detect Flag' (pin 17) serves two purposes. For one, it serves as a overflow flag when the count rolls over from 99,999,999 to 0. Secondly, it serves as a zero-reached flag when the counter decrements from 1 to 0. In both cases the flag is activated for 10uS.

**Important Note:** Although we strive to maintain a high degree of technical accuracy, this document may contain typographical errors or other inaccuracies. We reserve the right to correct any inaccuracy in future editions of this document without notice. This document and examples contained herein are provided 'As Is' without warranty of any kind expressed or implied. This document is to be used for informational purposes only and may not be duplicated for commercial purposes other than by distributors authorized by E-Lab Digital Engineering, Inc.

The EDE707 IC is implemented as firmware on a 0.7 micron-process RISC core. For a more comprehensive technical summary of this core device, please refer to the Microchip Technology PIC16C57C datasheet (available from the E-Lab web site).

**ABSOLUTE MAXIMUM RATINGS**

Oscillator frequency ..... 4 MHz  
Supply Voltage ..... 5.5V  
Max. current sunk by an output pin ..... 25mA  
Max. current sourced by an output pin ..... 20mA

**STANDARD OPERATING CONDITIONS**

Supply voltage ..... 4.5V to 5.5V  
Operating temperature ..... 0°C to +70°C

**IMPORTANT NOTICE**

E-LAB Digital Engineering, Inc. (E-LAB), reserves the right to change products or specifications without notice. Customers are advised to obtain the latest versions of product specifications, which should be considered when evaluating a product's appropriateness for a particular use.

THIS PRODUCT IS WARRANTED TO COMPLY WITH E-LAB'S SPECIFICATION SHEET AT THE TIME OF DELIVERY. BY USING THIS PRODUCT, CUSTOMER AGREES THAT IN NO EVENT SHALL E-LAB BE LIABLE FOR ANY DIRECT, INDIRECT, SPECIAL, INCIDENTAL OR CONSEQUENTIAL DAMAGES AS A RESULT OF THE PERFORMANCE, OR FAILURE TO PERFORM, OF THIS PRODUCT.

E-LAB MAKES NO OTHER WARRANTIES, EXPRESSED OR IMPLIED, INCLUDING ANY IMPLIED WARRANTIES OF MERCHANTABILITY OR FITNESS FOR A PARTICULAR PURPOSE.

E-LAB's LIABILITY IS FOR A PERIOD NO GREATER THAN 90 DAYS FROM DATE OF SHIPMENT BY E-LAB AND IS LIMITED TO REPLACEMENT OF DEFECTIVE PRODUCT. This warranty covers only defects arising under normal use and not malfunctions resulting from misuse, abuse, modification, or repairs by anyone other than E-LAB.

E-LAB'S PRODUCTS ARE NOT AUTHORIZED FOR USE AS CRITICAL COMPONENTS IN LIFE SUPPORT DEVICES OR SYSTEMS WITHOUT THE EXPRESS WRITTEN APPROVAL OF THE PRESIDENT OF E-LAB. Life support devices or systems are those which are intended to support or sustain life and whose failure to perform can be reasonably expected to result in a significant injury or death to the user. Critical components are those whose failure to perform can be reasonably expected to cause failure of a life support device or system or affect its safety or effectiveness.

**COPYRIGHT NOTICE**

This product may not be duplicated. E-LAB Digital Engineering, Inc. holds all copyrights on firmware, with all rights reserved. Unauthorized duplication of this device will be subject to penalty under state and/ or federal law.

EDE707 and the E-LAB logo are trademarks of E-LAB Digital Engineering, Inc. All other trademarks and registered trademarks are property of their respective owners.

**CONTACTING US**

We are continually updating our product line. Please contact us for our latest product information.

E-LAB Digital Engineering, Inc.  
Carefree Industrial Park  
1600 N. State Rte. 291 Hwy. Ste. 330  
Independence, MO 64056

Telephone: (816) 257-9954  
FAX: (816) 257-9945



Internet:  
[www.elabinc.com](http://www.elabinc.com)

E-Mail:  
[support@elabinc.com](mailto:support@elabinc.com)

*Engineering Design-In Support is available free of charge for the EDE707 Seven-Segment LED Display IC.*